



GR Series Dimensions

Styles: HMQ, HM, H

CAST IRON
GR SERIES

Single Reduction
Worm Gear Reducers

Double Reduction
Worm - Worm Gear Reducers

Double Reduction
Helical - Worm Gear Reducers

WASHGUARD® Reducers
and GEAR+MOTOR™

Ratio Multipliers

Accessories and
Additional Capabilities

Style HMQ

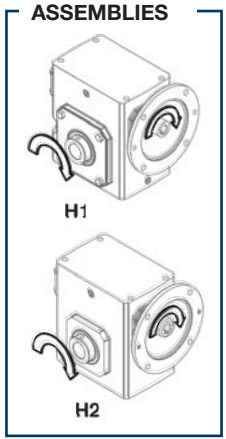
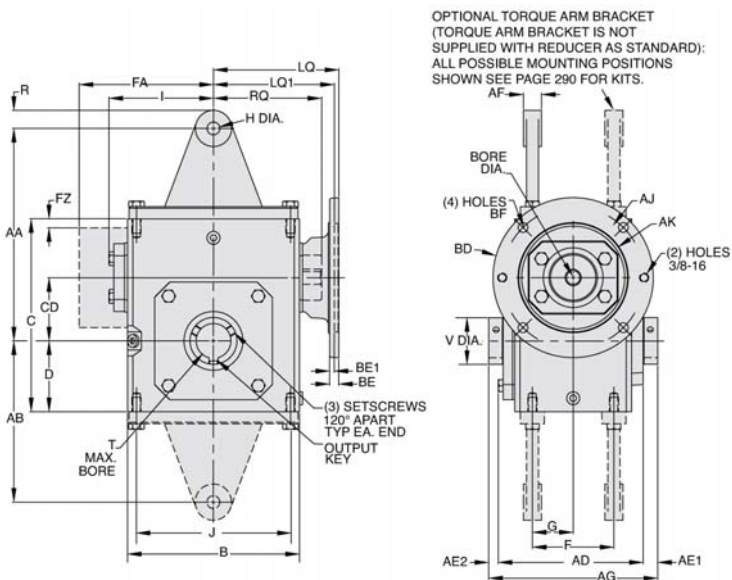

H1 SUPPLIED AS STANDARD UNLESS SPECIFIED.

Style HM

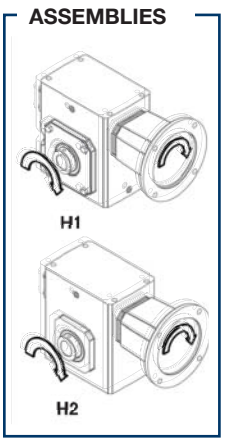
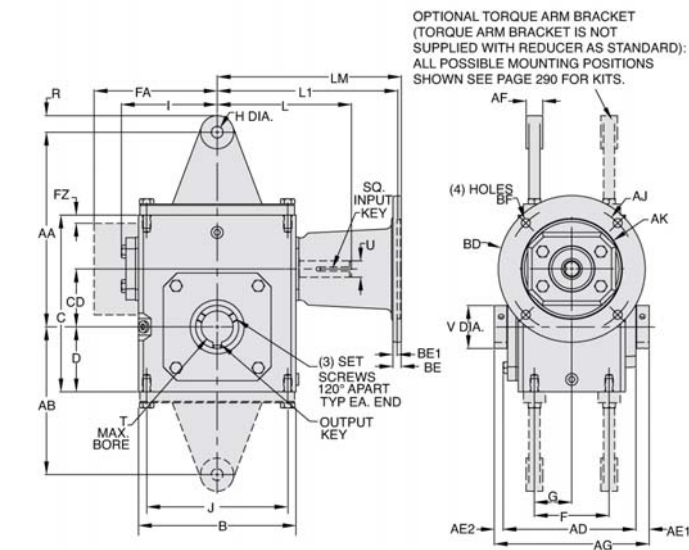

H1 SUPPLIED AS STANDARD UNLESS SPECIFIED.

Style H

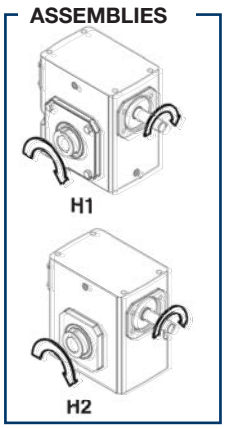
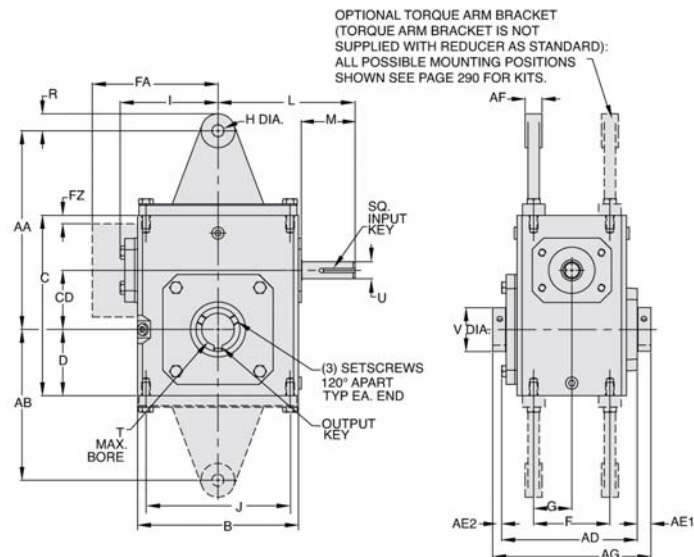

REVERSE ALL ARROWS FOR OPPOSITE INPUT SHAFT ROTATION. CONTACT FACTORY FOR OTHER MOUNTINGS OR ASSEMBLY POSITIONS.

H1 SUPPLIED AS STANDARD UNLESS SPECIFIED.



STYLE HMQ, HM, H DIMENSIONS (Inches)

Series	AD	AE1	AE2	AG	B	C	D	CD	F	FA▼	FZ▼	G	I	J	L	M	V	T MAX -0.000 +0.0025	U +0.000 -0.0015	Input Key*	Output Key +
GR813	3.90	0.53	0.32	4.75	3.80	4.66	1.72	1.33	2.00	N/A	N/A	1.00	2.61	3.25	3.82	1.76	1.000	0.625	0.500	1/8 x 1.00	3/16 x 1.50
GR815	4.61	0.51	0.30	5.42	5.19	5.38	1.91	1.54	2.75	N/A	N/A	1.38	3.14	4.19	4.35	1.76	1.000	0.625	0.625	3/16 x 1.38	3/16 x 1.50
GR818	4.73	0.49	0.28	5.50	5.19	5.75	2.06	1.75	2.75	N/A	N/A	1.38	3.24	4.19	4.45	1.76	1.440	1.000	0.625	3/16 x 1.38	1/4 x 3.00
GR821	4.99	0.61	0.40	6.00	5.80	6.38	2.28	2.06	▲	N/A	N/A	1.44	3.61	▲	4.82	1.76	1.940	1.500	0.625	3/16 x 1.38	3/8 x 3.00
GR824	5.18	0.51	0.31	6.00	6.12	6.94	2.50	2.38	2.88	N/A	N/A	1.44	3.77	5.00	5.51	2.38	1.940	1.500	0.750	3/16 x 1.63	3/8 x 3.00
GR826x	6.01	0.60	0.39	7.00	7.38	8.00	2.94	2.63	3.38	N/A	N/A	1.69	4.34	6.38	6.07	2.38	1.940	1.500	0.750	3/16 x 1.63	3/8 x 3.00
GR830	6.53	0.60	0.36	7.50	8.12	8.88	3.25	3.00	4.00	N/A	N/A	2.00	4.84	7.00	6.57	2.38	2.756	2.188	0.875	3/16 x 1.63	1/2 x 3.00
GR832x	7.04	0.54	0.29	7.88	8.75	9.38	3.50	3.25	4.00	N/A	N/A	2.00	5.02	7.50	6.76	2.38	2.756	2.188	0.875	3/16 x 1.63	1/2 x 3.00
GR842	7.53	0.63	0.34	8.50	10.25	11.38	4.44	4.25	5.00	N/A	N/A	2.50	6.10	8.50	9.57	3.47	2.756	2.188	1.250	1/4 x 2.50	1/2 x 3.00
GR852	8.85	0.97	0.68	10.50	13.00	14.00	5.12	5.25	5.81	N/A	N/A	2.91	7.50	11.00	10.88	3.38	4.260	3.438	1.250	1/4 x3.00	7/8 x3.44
GR860	10.52	0.52	0.52	11.50	14.50	16.50	6.50	6.00	6.38	11.13	0.33	3.19	N/A	12.75	11.78	3.41	4.256	3.438	1.500	3/8 x 3.00	7/8 x 3.44
GR870	11.36	1.09	1.09	13.50	14.88	18.91	7.59	7.00	5.50	11.37	0.35	2.75	N/A	12.50	11.50	2.97	4.928	3.938	1.625	3/8 x 2.87**	1 x 1/2**
GR880	12.48	1.03	1.03	14.50	17.00	20.96	8.86	8.00	6.50	12.52	0.57	3.25	N/A	14.25	12.50	2.84	5.553	4.438	1.875	1/2 x 2.81**	1 x 1/2**
GR8100	15.78	1.39	1.39	18.50	20.88	25.47	10.36	10.00	6.88	14.69	0.51	3.44	N/A	14.75	15.50	3.76	4.256	5.438	2.250	1/2 x 3.69**	1-1/4 x 5/8**

▲ See feature comparison chart.

FEATURE COMPARISON (821)

Size	Output Shaft Diameter Needed?	Mounting Footprint Needed?	Output Key Needed?	All Other Features	Grove Gear Flexaline Interchange	LEESON IRONMAN Interchange	Replace With Series Code Below:
GR821	Identical	(F)3.00" x (J)4.75"	Identical	Identical	✓	✓	GRG
		(F)2.88" x (J)5.00"					GRL

NOTE: If reducer is used without the accessory mounted, select based mounting dimensions on pages 52-53 (B, BM, BMQ).

**Motor Mounting Dimensions
NEMA DIMENSIONS (Inches)**

Size	48CZ	LM	56C/140TC	180TC/210TC	L1	250TC	LQ	48CZ/56C/140TC	180TC	LQ1	210TC	250TC	48CZ/56C/140TC	180TC	RQ	210TC	250TC
GR813	5.63	6.07	N/A	N/A	N/A	N/A	3.46	N/A	N/A	N/A	N/A	N/A	3.09	N/A	N/A	N/A	N/A
GR815	6.16	6.60	N/A	N/A	N/A	N/A	3.99	N/A	N/A	N/A	N/A	N/A	3.62	N/A	N/A	N/A	N/A
GR818	6.26	6.70	N/A	N/A	N/A	N/A	4.09	N/A	N/A	N/A	N/A	N/A	3.59	N/A	N/A	N/A	N/A
GR821*	6.63	7.07	N/A	N/A	N/A	N/A	4.46	N/A	N/A	N/A	N/A	N/A	4.06	N/A	N/A	N/A	N/A
GR824	N/A	7.76	8.76	N/A	4.63	5.06	N/A	N/A	4.09	4.56	N/A	N/A	N/A	N/A	N/A	N/A	N/A
GR826*	N/A	8.32	9.32	N/A	5.19	5.62	N/A	N/A	4.82	5.13	N/A	N/A	N/A	N/A	N/A	N/A	N/A
GR830	N/A	8.82	9.82	N/A	5.95	6.15	6.56	N/A	5.32	5.63	6.06	N/A	N/A	N/A	N/A	N/A	N/A
GR832*	N/A	9.01	10.01	N/A	6.14	6.34	6.75	N/A	5.51	5.81	6.25	N/A	N/A	N/A	N/A	N/A	N/A
GR842	N/A	11.81	12.90	13.46	6.45	7.21	7.21	7.77	6.04	6.68	6.68	7.24	N/A	N/A	N/A	N/A	N/A
GR852	N/A	13.21	14.30	14.86	7.85	8.61	8.61	9.17	7.35	7.98	7.98	8.54	N/A	N/A	N/A	N/A	N/A
GR860	N/A	N/A	15.88	16.50	10.45	9.33	9.33	9.94	10.01	8.69	8.69	8.69	N/A	N/A	N/A	N/A	N/A
GR870	N/A	N/A	15.50	15.50	N/A	N/A	N/A	N/A	N/A	N/A	N/A	N/A	N/A	N/A	N/A	N/A	N/A
GR880	N/A	N/A	16.58	16.58	N/A	N/A	N/A	N/A	N/A	N/A	N/A	N/A	N/A	N/A	N/A	N/A	N/A

NEMA DIMENSIONS (Inches)

Frame	AJb	AK	BD	BE	BE1	Bore Dia.	Keyway♦	BFb
	3.75	3.00	4.36	0.38	N/A	.500	1/8 X 1/16	0.28
56C	5.88	4.50	6.50	0.38	N/A	.625	3/16 X 3/32	0.41
140TC	5.88	4.50	6.50	0.38	N/A	.875	3/16 X 3/32	0.41
180TC	7.25	8.50	9.00	N/A	0.50	1.125	1/4 X 1/8	0.53
210TC	7.25	8.50	9.00	N/A	0.50	1.375	5/16 X 5/32	0.53
250TC	7.25	8.50	9.00	N/A	0.50	1.625	3/8 X 3/16	0.53

IEC B5 & B3/B5 METRIC DIMENSIONS (Inches)*

Size	LQ1						RQ					
	D63D	D71D	D80D	D90D	D100LD/D112MD	D132D	D63D	D71D	D80D	D90D	D100LD/D112MD	D132D
GR813	2.62	2.65	2.89	N/A	N/A	N/A	2.45	2.47	2.71	N/A	N/A	N/A
GR815	3.15	3.18	3.42	N/A	N/A	N/A	2.98	3.00	3.24	N/A	N/A	N/A
GR818	3.25	3.28	3.52	N/A	N/A	N/A	2.95	2.97	3.21	N/A	N/A	N/A
GR821*	3.62	3.65	3.89	N/A	N/A	N/A	3.43	3.44	3.68	N/A	N/A	N/A
GR824	N/A	3.72	4.34	N/A	N/A	N/A	3.46	3.71	N/A	N/A	N/A	N/A
GR826*	N/A	4.28	4.90	4.90	5.30	N/A	N/A	4.09	4.72	4.72	5.07	N/A
GR830	N/A	4.78	5.41	5.41	5.88	N/A	N/A	4.59	5.22	5.22	5.57	N/A
GR832*	N/A	4.97	5.59	5.59	6.07	N/A	N/A	4.78	5.41	5.41	5.76	N/A
GR842	N/A	N/A	N/A	6.38	6.39	7.17	N/A	N/A	N/A	6.16	6.14	6.93
GR852	N/A	N/A	N/A	7.78	7.78	8.57	N/A	N/A	N/A	7.46	7.45	8.24

IEC B5 & B3/B5 METRIC DIMENSIONS (MM)

Frame	AJ	AK	BD	BE	Bore Dia.	Keyway♦	BF TAP	OD
D63D	115	95	117	10	11	4 X 2	M8 X 1.25	131
D71D	130	110	132	11	14	5 X 2.5	M8 X 1.25	146
D80D	165	130	165	15	19	6 X 3	M10 X 1.50	184
D90D	165	130	165	15	24	8 X 3.5	M10 X 1.50	184
D100LD/D112MD	215	180	216	18	28	8 X 3.5	M12 X 1.75	237
D132D	265	230	267	18	38	10 X 4	M12 X 1.75	290

* Max bore dimensions shown. For additional bores available, refer to page 20.

* Applies to double output shaft

** Key not provided with gear reducer. Keyway dimension shown.

♦ Keyway width by depth

⊙ Mounting holes rotated 45 degrees from positions shown on Size GR860, Style HM with frame sizes 180TC-250TC.

■ 48CZ not available

● 180TC not available

⊕ Metric IEC B5 input flange options are available only on quill input styles.

* Dimensions same for GRG and GRL Series

* Style H and HM only.

▼ Sizes 860-8100 are supplied with a fan. Dimensions refer to fan guard location.

Note: Torque arm bracket available separately. Refer to page 274 for kits. If a special bracket is required, refer to Style BMQ dimensions for mounting pad dimensions on top/bottom of reducer.



For safety, purchaser or user should provide protective guards over shaft extensions and any couplings, sheaves and belts, sprockets and chains, etc., mounted thereon.

Single Reduction
Worm Gear Reducers

Double Reduction
Worm - Worm Gear Reducers

Double Reduction
Helical - Worm Gear Reducers

WASHGARD® Reducers
and GEAR-HMOTOR™

Ratio Multipliers

Accessories and
Additional Capabilities

Style WBMQ

Style WHMQ



826 Series

Ratio	Input RPM	Output RPM+	Input HP	Output HP	Output Torque (lb-in)	NEMA C Input Frame▲	Left Hand Catalog No.	Right Hand Catalog No.	Double Extension Catalog No.	Hollow Output Catalog No.*
5 <small>(5.17 actual)</small>	1750	350.0	6.693	6.276	1130	143-5TC	<u>8263037</u>	<u>8263049</u>	<u>8263061</u>	<u>8263513.XX</u>
7.5	1750	233.3	4.956	4.571	1235	143-5TC	<u>8263038</u>	<u>8263050</u>	<u>8263062</u>	<u>8263514.XX</u>
10	1750	175.0	4.492	4.097	1475	143-5TC	<u>8263039</u>	<u>8263051</u>	<u>8263063</u>	<u>8263515.XX</u>
15	1750	116.7	3.614	3.216	1737	143-5TC	<u>8263040</u>	<u>8263052</u>	<u>8263064</u>	<u>8263516.XX</u>
20	1750	87.5	2.965	2.549	1836	56C	<u>8263005</u>	<u>8263017</u>	<u>8263029</u>	<u>8263505.XX</u>
						143-5TC	<u>8263041</u>	<u>8263053</u>	<u>8263065</u>	<u>8263517.XX</u>
25	1750	70.0	2.487	2.076	1869	56C	<u>8263006</u>	<u>8263018</u>	<u>8263030</u>	<u>8263506.XX</u>
						143-5TC	<u>8263042</u>	<u>8263054</u>	<u>8263066</u>	<u>8263518.XX</u>
30	1750	58.3	2.145	1.743	1883	56C	<u>8263007</u>	<u>8263019</u>	<u>8263031</u>	<u>8263507.XX</u>
						143-5TC	<u>8263043</u>	<u>8263055</u>	<u>8263067</u>	<u>8263519.XX</u>
40	1750	43.8	1.695	1.287	1854	56C	<u>8263008</u>	<u>8263020</u>	<u>8263032</u>	<u>8263508.XX</u>
						143-5TC	<u>8263044</u>	<u>8263056</u>	<u>8263068</u>	<u>8263520.XX</u>
50	1750	35.0	1.420	1.023	1843	56C	<u>8263009</u>	<u>8263021</u>	<u>8263033</u>	<u>8263509.XX</u>
						143-5TC	<u>8263045</u>	<u>8263057</u>	<u>8263069</u>	<u>8263521.XX</u>
60	1750	29.2	1.216	0.835	1805	56C	<u>8263010</u>	<u>8263022</u>	<u>8263034</u>	<u>8263510.XX</u>
						143-5TC	<u>8263046</u>	<u>8263058</u>	<u>8263070</u>	<u>8263522.XX</u>
80	1750	21.9	0.577	0.379	1092	56C	<u>8263011</u>	<u>8263023</u>	<u>8263035</u>	<u>8263511.XX</u>
							<u>8263012</u>	<u>8263024</u>	<u>8263036</u>	<u>8263512.XX</u>

For input/ output shaft overhung load and thrust load ratings, refer to pages 419-422.

▲ Contact Factory for other motor flanges available.

+ For gear reducer ratings at other input speeds, refer to basic reducer selection tables on pages 32-33.

How To Build a Part Number For Size GR826, GRG826, GRL826, EL826

1. Select partial catalog number from the selection table
2. Replace leading “_” with series code (GR, GRG, GRL, EL)
3. For Hollow output, replace “XX” suffix with bore code.

Example:

GR Series Style WBMQ, 10:1 Left Hand Output, 140TC
GRG-WBMQ826-10-L-140, GRG8263039

GRG = GROVE GEAR

- Direct replacement to Grove Gear Flexaline
- 1-1/4” solid output shaft diameter
- For hollow bores, specify GRL Interchange
- Solid output shaft only



GRL = IRONMAN Interchange

- Direct replacement to LEESON IRON-MAN & major brands.
- Hollow shaft option available
- 1-1/8” solid output shaft diameter

Available bore codes

Fraction Size	1”	1-1/8”	1-3/16”	1-1/4”	1-7/16”	1-1/2”
Decimal Size	1.000	1.125	1.188	1.250	1.438	1.500
Output Bore Code	16	18	19	20	23	24

* Catalog numbers are for hollow output shaft reducers.

When ordering, substitute the XX suffix with the required output bore code.

Single Reduction
Worm Gear Reducers

Double Reduction
Worm - Worm Gear Reducers

Double Reduction
Helical - Worm Gear Reducers

WASHGUARD® Reducers
and GEAR+MOTOR™

Ratio Multipliers

Accessories and
Additional Capabilities